

ASSEMBLING INSTRUCTION

LICENCE PLATE

HX7104-21

WWW.BARRACUDAMOTO.COM

LEGEND

- | | | |
|---|--|---|
| 1. LICENCE PLATE BRACKET
STAFFA PORTATARGA
SOPORTE DE LA PLACA
NUMMERSCHILD HALTERUNG
SUPPORT DE PLAQUE | 5. ALLEN SCREW M8X12
VITE A BRUGOLA M8X12
TORNILLO ALLEN M8X12
INBUSSCHRAUBE M8X12
VIS ALLEN M8X12 | 9. NUT Ø 5
DADO Ø 5
TUERCA Ø 5
MUTTER Ø 5
ÉCROU Ø 5 |
| 2. LOCK BRACKET
STAFFA SERRATURA
SOPORTE DE BLOQUEO
VERRIEGELUNG HALTERUNG
SUPPORT DE VERROUILLAGE | 6. ALLEN SCREW M5X16
VITE A BRUGOLA M5X16
TORNILLO ALLEN M5X16
INBUSSCHRAUBE M5X16
VIS ALLEN M5X16 | 10. JOINT PLATE HOLDER
SNODO PORTATARGA
ARTICULACIÓN PLACA
GELENK PLATTENHALTER
SUPPORT DE PLAQUE |
| 3. ALLEN SCREW M8X16
VITE A BRUGOLA M8X16
TORNILLO ALLEN M8X16
INBUSSCHRAUBE M8X16
VIS ALLEN M8X16 | 7. NUT Ø 5
DADO Ø 5
TUERCA Ø 5
MUTTER Ø 5
ÉCROU Ø 5 | 11. LOCK COVER
COVER SERRATURA
COVER DE BLOQUEO
ABDECKUNGS VERRIEGELUNG
COVER DE VERROUILLAGE |
| 4. BRACKET COVER
COVER STAFFA
COVER DE SOPORTE
ABDECKUNGSHALTERUNG
COVER DE SUPPORT | 8. ALLEN SCREW M5X12
VITE A BRUGOLA M5X12
TORNILLO ALLEN M5X12
INBUSSCHRAUBE M5X12
VIS ALLEN M5X12 | 12. ALLEN SCREW M5X14
VITE A BRUGOLA M5X14
TORNILLO ALLEN M5X14
INBUSSCHRAUBE M5X14
VIS ALLEN M5X14 |

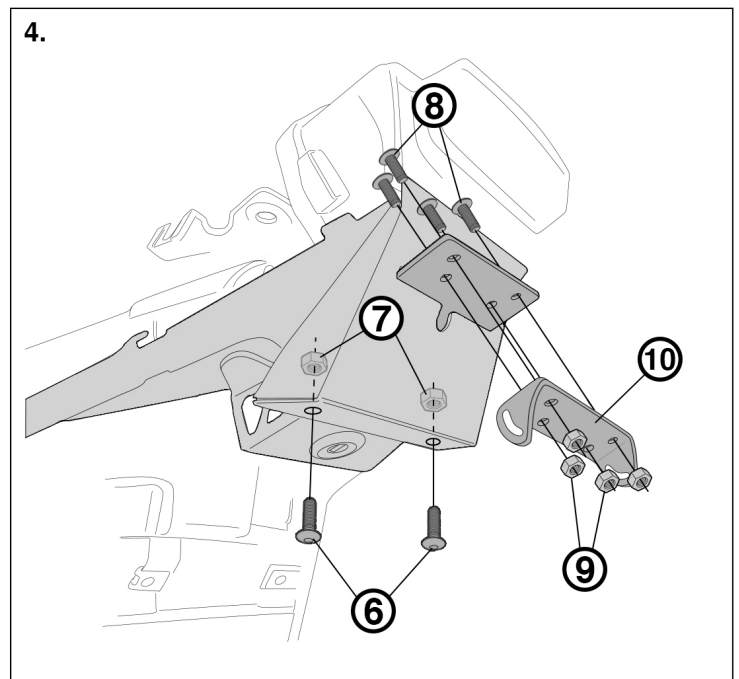
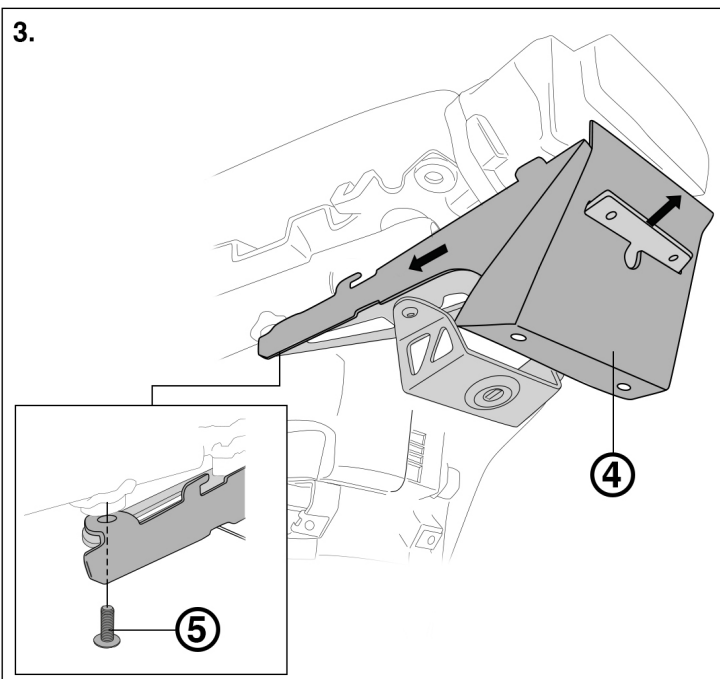
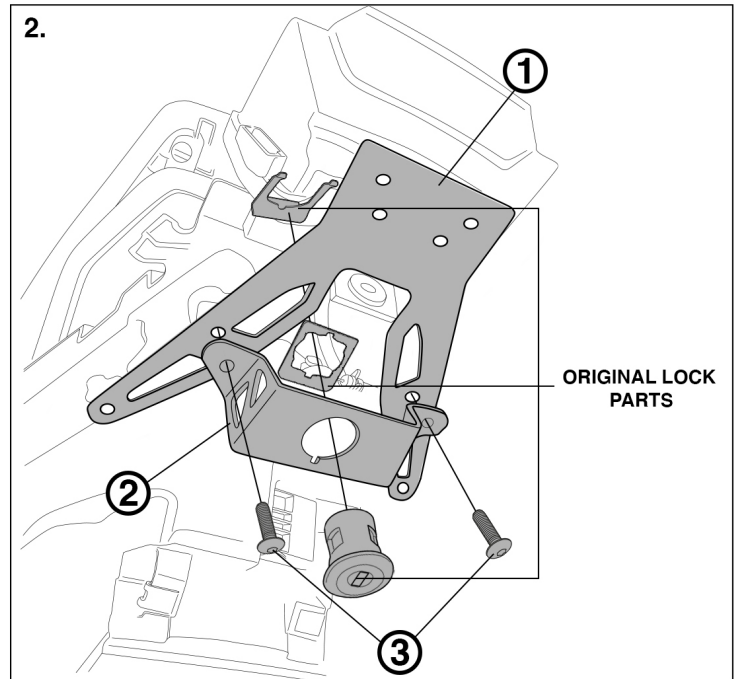
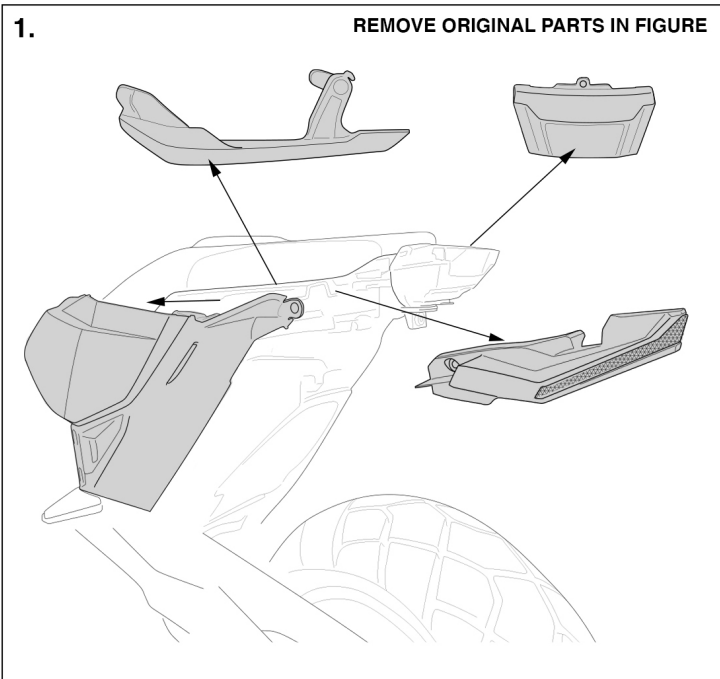

5. REASSEMBLE THE ORIGINAL SIDE FAIRINGS

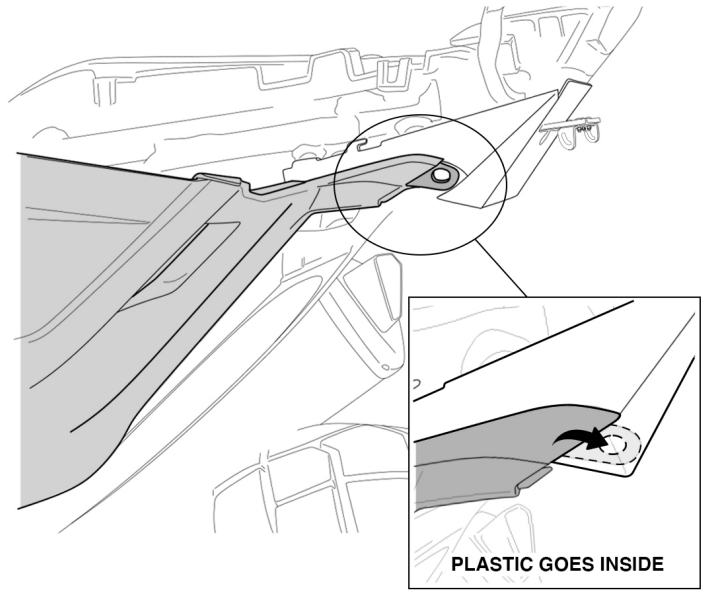

6.

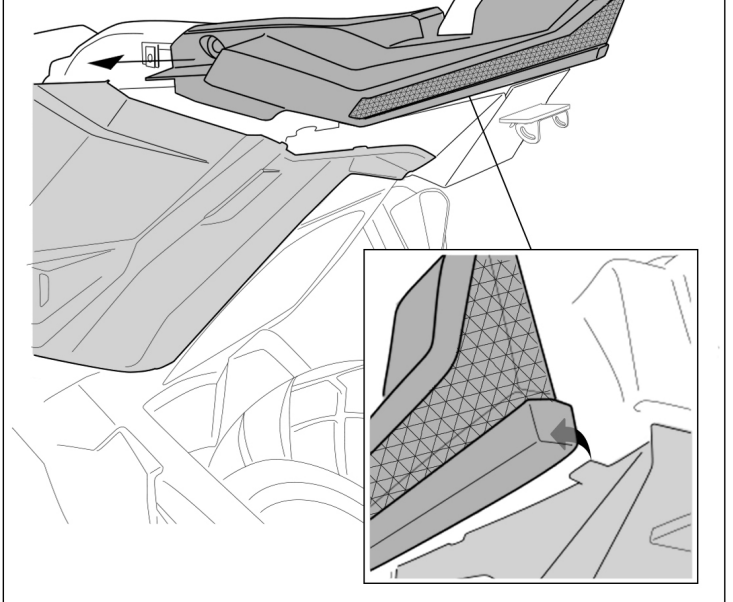

7. REASSEMBLE THE ORIGINAL PARTS

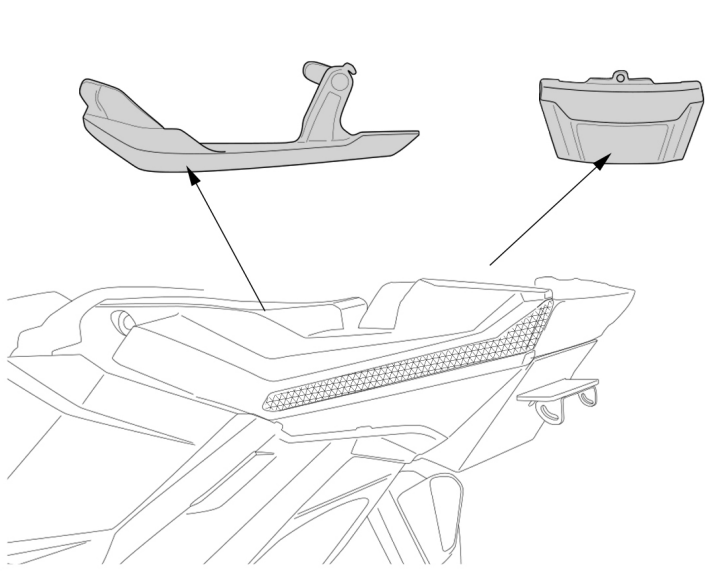

8.

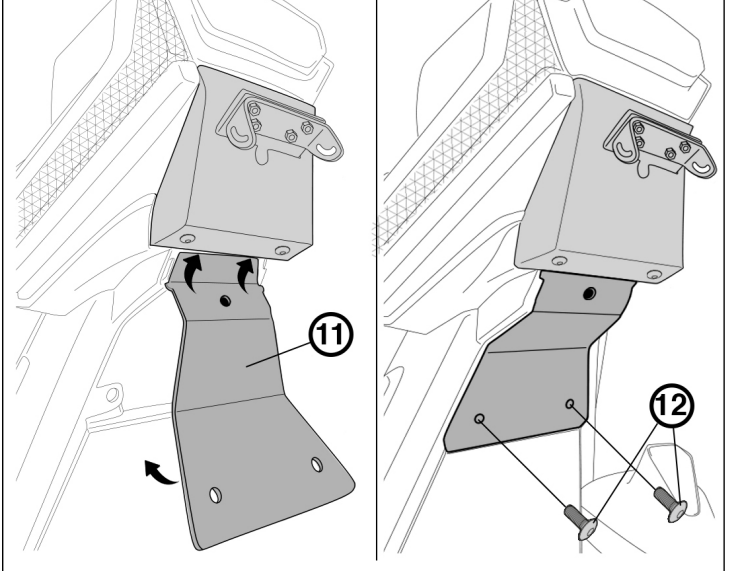

9.

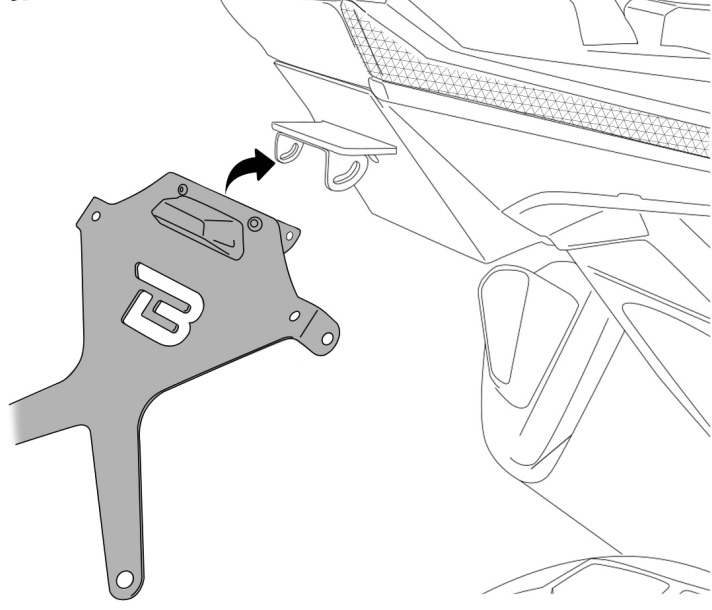

EN: DO NOT MOUNT ADDITIONAL PARTS OR PLATES TO THE X PLATE TO AVOID EXTRA WEIGHT AND POSSIBLE BREAKINGS.

IT: NON MONTARE PIASTRE E/O ULTERIORI ELEMENTI ALLA X TARGA PER EVITARE APPESANTIMENTI E POSSIBILI ROTTURE.

ES: NO MONTE PIEZAS O PLACAS ADICIONALES EN LA PLACA X PARA EVITAR PESO ADICIONAL Y POSIBLES ROTURAS.

DE: MONTIEREN SIE KEINE ZUSÄTZLICHEN TEILE ODER PLATTEN AN DER X-PLATTE, UM ZUSÄTZLICHES GEWICHT UND MÖGLICHE BRÜCHE ZU VERMEIDEN.

FR: NE MONTEZ PAS DE PIÈCES OU DE PLAQUES SUPPLÉMENTAIRES SUR LA PLAQUE X POUR ÉVITER UN POIDS SUPPLÉMENTAIRE ET D'ÉVENTUELLES CASSURES.

EN: WE RECOMMEND AN INCLINATION NOT MORE THAN 30° TO AVOID PENALTIES AND POSSIBLE STRUCTURAL DAMAGES.

IT: CONSIGLIAMO UN'INCLINAZIONE NON SUPERIORE AI 30° PER EVITARE SANZIONI E POSSIBILI DANNI STRUTTURALI.

ES: RECOMENDAMOS UNA INCLINACIÓN DE NO MÁS DE 30° PARA EVITAR SANCIONES Y POSIBLES DAÑOS ESTRUCTURALES.

DE: WIR EMPFEHLEN EINE STEIGUNG VON NICHT MEHR ALS 30°, UM STRAFEN UND MÖGLICHE STRUKTURELLE SCHÄDEN ZU VERMEIDEN.

FR: NOUS VOUS RECOMMANDONS DE NE PAS INCLINER À PLUS DE 30° POUR ÉVITER LES PÉNALITÉS ET LES DOMMAGES STRUCTURELS POSSIBLES.